

# SPECIFICATIONS

## ELECTRICAL

FREQUENCY: DC-25 GHZ  
 IMPEDANCE: 50 OHMS  
 VRMS: 500 VOLTS

## MECHANICAL

MATERIALS BODY: BRASS, STAINLESS STEEL  
 OR PASSIVATED  
 MALE CONTACTS: BRASS OR BeCu  
 FEMALE CONTACTS: BeCu  
 GASKETS: SILICONE RUBBER  
 INSULATOR: TEFLON

SSMA-F

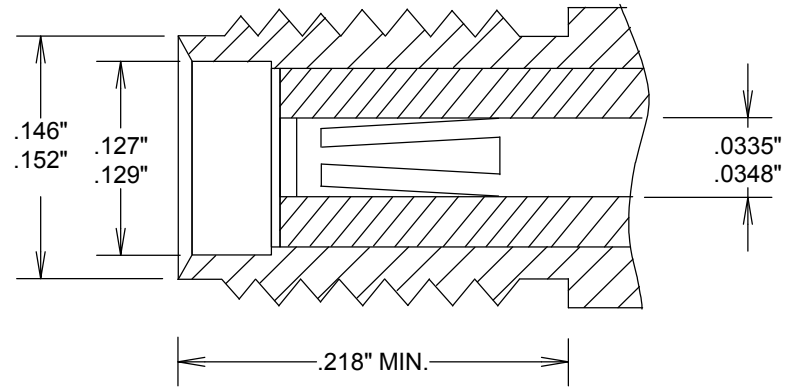

**S. M. ELECTRONICS L.L.C**  
 FAIRVIEW, TX 75069 WWW.SMELECTRONICS.US

TITLE

**SSMA-F**

SIZE	CAGE CODE	DWG NO	REV
<b>A</b>	<b>3FKR5</b>	<b>SSMA-F CONNECTOR</b>	<b>--</b>
SCALE		SHEET	