

# C-MALE

## SPECIFICATIONS

### ELECTRICAL

FREQUENCY: 0-11 GHZ  
 IMPEDANCE: 50 75 OHMS  
 VRMS: 500 V SEA LEVEL

### MECHANICAL

MATERIALS BODY: NICKEL PLATED BRASS  
 MALE CONTACTS: BRASS  
 FEMALE CONTACTS: BeCu  
 GASKETS: SILICONE RUBBER  
 INSULATOR: TEFLON

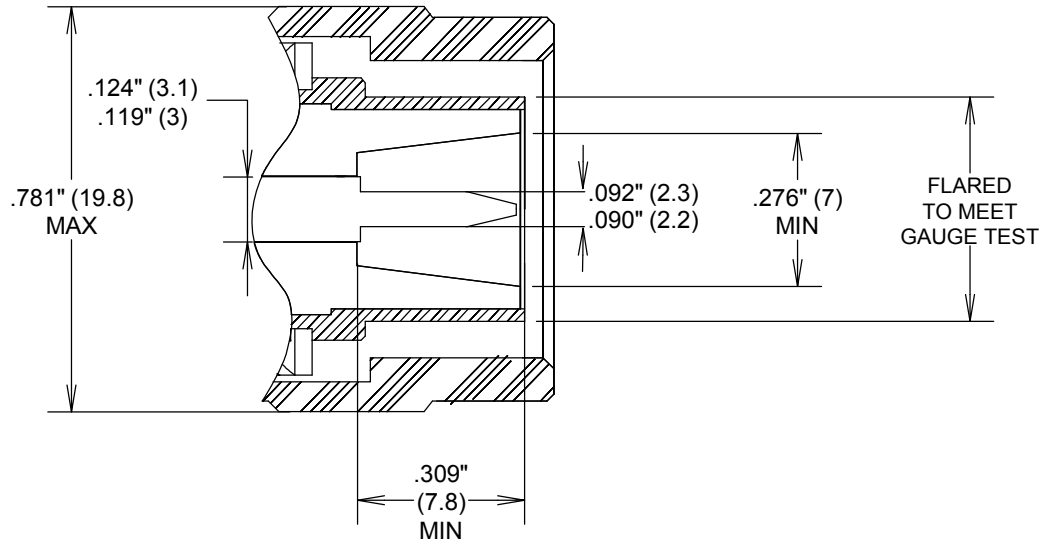

<b>FAIRVIEW MICROWAVE INC.</b>			
ALLEN, TX 75013 WWW.FAIRVIEWMICROWAVE.COM			
TITLE			
<b>C-MALE</b>			
SIZE	CAGE CODE	DWG NO	REV
<b>A</b>	<b>3FKR5</b>	<b>C-M CONNECTOR</b>	<b>--</b>
SCALE		SHEET	

ALL DIMENSIONS IN inches(mm) Typical