

6

5

4

3

2

1

INSTALLATION INSTRUCTION

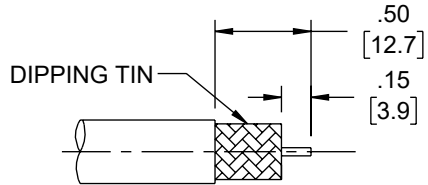

1. TRIM CABLE TO DIMENSIONS SHOWN. BE CAREFUL TO AVOID NICKING THE INNER AND OUTER CONDUCTOR. CONNECTOR ADDS: 15.7mm [0.618"]

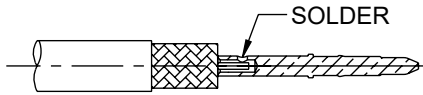

2. A. PUT ON THE PIN.
B. SOLDER THE INNER CONDUCTOR.

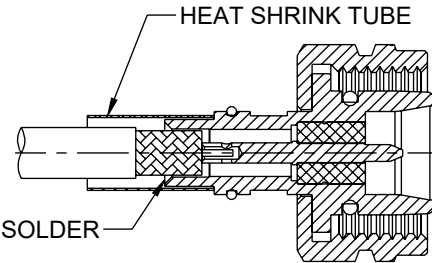

3. A. PUT ON THE HEAT SHRINK TUBE.
B. PRESS THE PIN INTO THE BODY.
C. SOLDER THE OUTER CONDUCTOR.
D. HEAT SHRINK TUBE OVER REAR OF CONNECTOR BODY AND DOWN ON TO CABLE JACKET USING HOT AIR GUN.

PLEASE NOTE: IT'S IMPORTANT THAT THE SOLDERING OF THE OUTER BRAID IS VOID FREE AT THE BOTTOM OF THE CABLE ENTRY HOLE. USING INDUCTION SOLDERING EQUIPMENT HELPS TO BRING THE WHOLE CONNECTOR BODY UP TO TEMPERATURE. IF YOU ARE USING RESISTANCE TWEEZERS OF A TRADITIONAL SOLDERING IRON, YOU WILL WANT TO MAKE SURE THAT YOU APPLY THE HEAT IN SUCH A WAY THAT THE SOLDER WILL FLOW TO THE BOTTOM OF THE CABLE ENTRY HOLE.
TIN DIPPING THE VERY END OF THE CABLE PRIOR TO PREPPING WILL HELP THE SOLDER EVENLY DISTRIBUTE AND BE VOID FREE.

THE INFORMATION CONTAINED IN THIS DRAWING IS THE SOLE PROPERTY OF INFINITE ELECTRONICS, INC. ANY REPRODUCTION IN PART OR WHOLE WITHOUT THE WRITTEN PERMISSION OF INFINITE ELECTRONICS, INC. IS PROHIBITED. THESE COMMODITIES, TECHNOLOGY OR SOFTWARE WERE EXPORTED FROM THE UNITED STATES IN ACCORDANCE WITH THE EXPORT ADMINISTRATION REGULATIONS. DIVERSION CONTRARY TO U.S. LAW PROHIBITED.

REVISION					
ZONE	REV	DESCRIPTION	DATE	CHANGED BY	APPROVED
	C	UPDATED PER ECO-14326	3/5/2025	HBAKKE	SRAUTUS

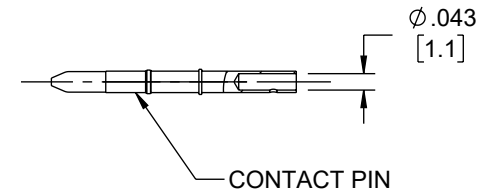
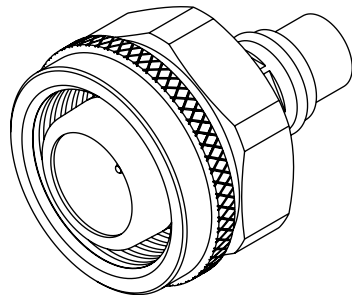
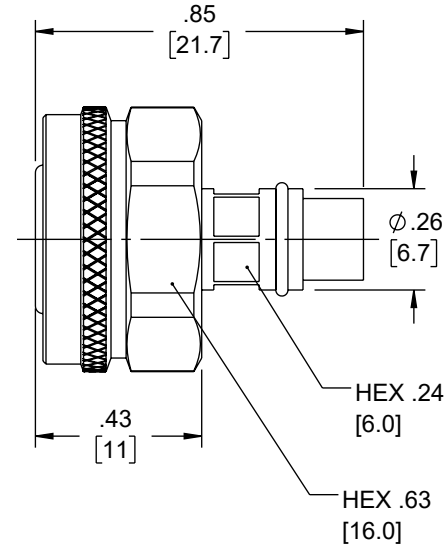
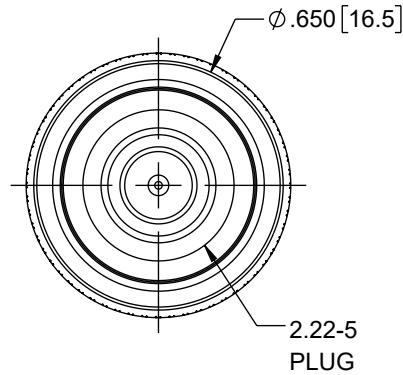

UNLESS OTHERWISE SPECIFIED LEADING DIMENSIONS ARE INCHES DIMENSIONS IN [] ARE MILLIMETERS

TOLERANCES:

X = ±.2 [5]	FRACTIONS ± 1/32
XX = ±.02 [0.5]	ANGLES ± 1°
.XXX = ±.005 [0.13]	

CABLE LENGTH TOLERANCES:

≤12 [305]	= +1 [25] / -0
>12 [305] ≤ 60 [1524]	= +2 [51] / -0
>60 [1524] ≤ 120 [3048]	= +4 [102] / -0
>120 [3048] ≤ 300 [7620]	= +6 [152] / -0
>300 [7620]	= +5% / -0

ALL DIMENSIONS ARE FOR REFERENCE ONLY AND SUBJECT TO CHANGE WITHOUT NOTICE UN-DIMENSIONED/NON-CRITICAL FEATURES MAY VARY IN SIZE AND LOCATION COLORS MAY VARY

Fairview Microwave
an INFINIT@ brand

Website: www.FairviewMicrowave.com
Phone: 1.800.715.4396 | 1.972.649.6678

INTERPRET ALL DIMENSIONS AND TOLERANCES PER ASME Y14.5

SCALE	SHEET
NONE	1 OF 1

DESCRIPTION

2.2-5 MALE LOW PIM CONNECTOR SOLDER ATTACHMENT FOR TFT-5G-402

SIZE	CAGE CODE	DRAWN BY	ITEM NO.	REV
A	3FKR5	DMAY	TC-402-225M-LP	C

6

5

4

3

2

1