

REVISIONS			
REV.	DESCRIPTION	DATE	APPROVED
A	INITIAL RELEASE	10/13/2020	T. GALLA

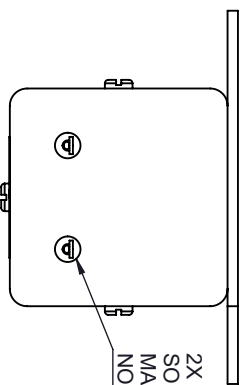

2X SOLDER TERMINALS.  
SOLDER WIRE USING SN96,  
MAXIMUM TEMP 250 °C FOR  
NO MORE THAN 5 SEC.

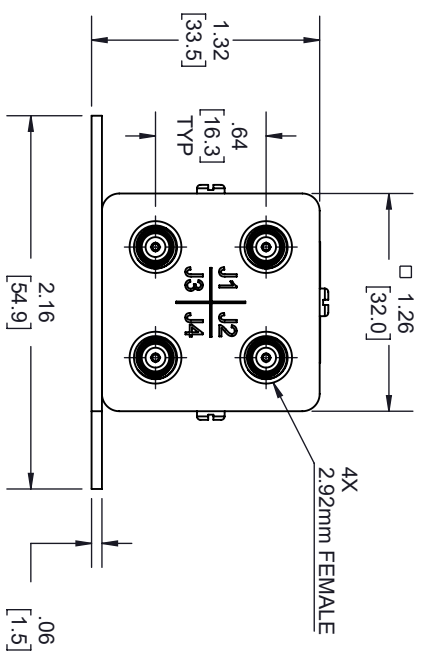
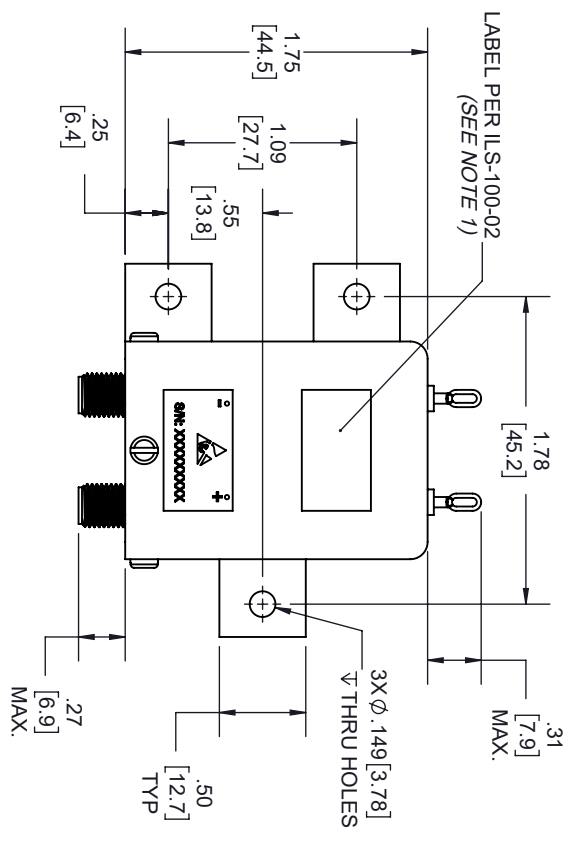
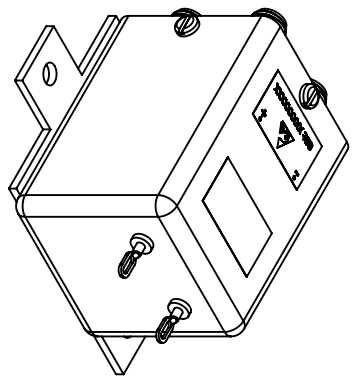
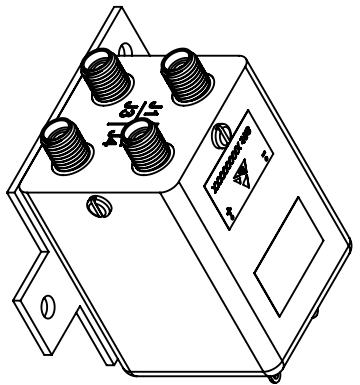

**NOTES:**

- LABEL PER ILS-100-02. FOR INTERNAL REFERENCE ONLY.  
LABEL LOCATION FOR REFERENCE ONLY.

THESE COMMODITIES, TECHNOLOGY OR SOFTWARE WERE EXPORTED FROM THE UNITED STATES IN ACCORDANCE WITH THE EXPORT ADMINISTRATION REGULATIONS, DIVERSION CONTRARY TO U.S. LAW PROHIBITED.



TITLE

UNLESS OTHERWISE SPECIFIED LEADING DIMENSIONS ARE INCHES  
DIMENSIONS IN [ ] ARE MILLIMETERS

THIRD-ANGLE PROJECTION

TOLERANCES:  
CABLE LENGTH (L) TOLERANCES:  
L ≤ 12 (305) = +1 [25] / -0  
12 (305) < L ≤ 60 (1524) = +2 [51] / -0  
60 (1524) < L ≤ 120 (3048) = +4 [102] / -0  
120 (3048) < L ≤ 300 (7620) = +6 [152] / -0  
300 (7620) < L = +5%L / -0

ALL DIMENSIONS SHOWN ARE FOR REFERENCE ONLY.

SCALE N/A

SIZE	GAGE CODE	DRAWN BY	ITEM NO.	REV
A	3FKRS	K.DANG	FMSW6432	A