

REVISIONS			
REV.	DESCRIPTION	DATE	APPROVED
A	INITIAL RELEASE	02/11/2022	A.GANWANI

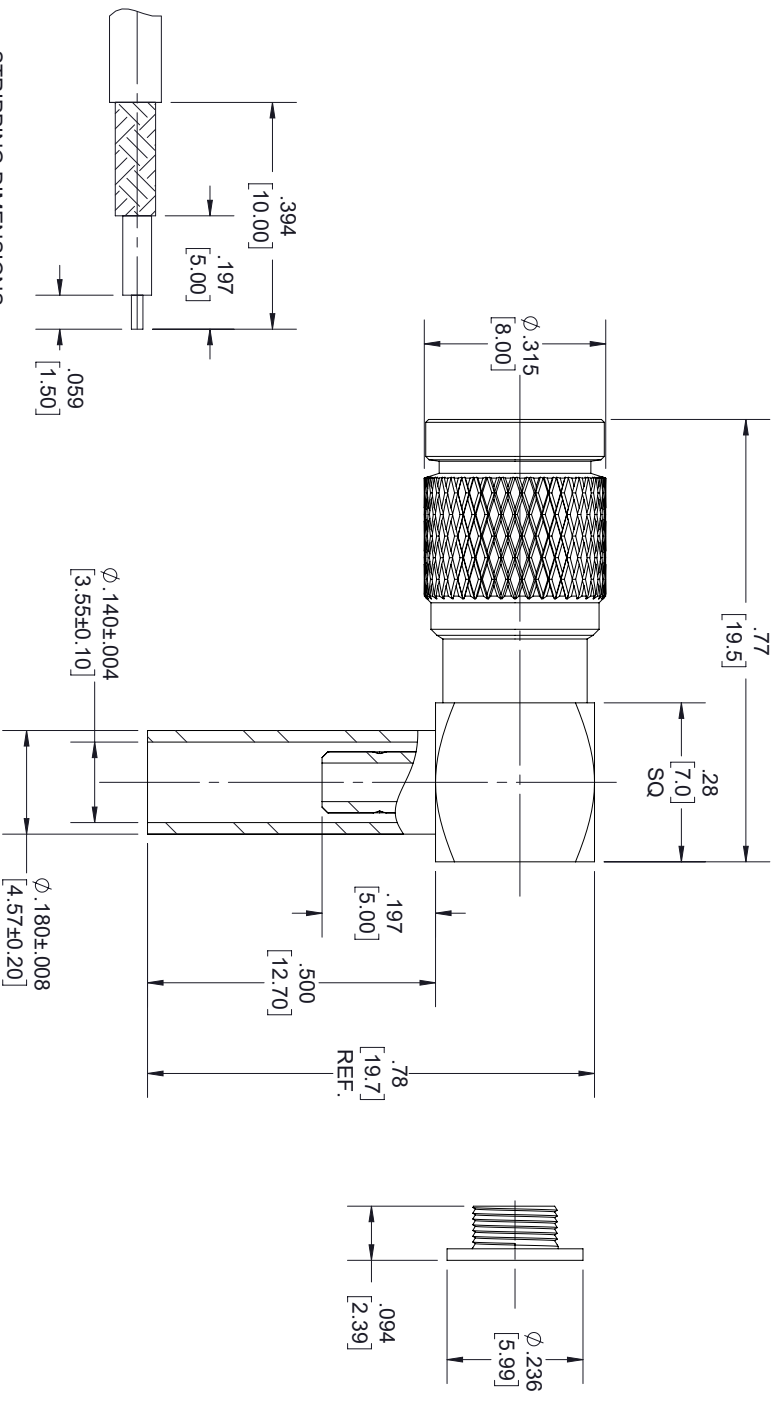

STRIPPING DIMENSIONS

NOTES:

1. CABLE ATTACHMENT:
 - OUTER: CRIMP.
 - INNER: SOLDER.
2. CRIMP SIZE REQUIRED:
FERRULE: .151" [3.84] HEX. CRIMP TOOL
ASSEMBLY PROCEDURES
 1. STRIP CABLE AS SHOWN. SLIDE FERRULE OVER CABLE.
 2. INSTALL CABLE INTO BODY OF CONNECTOR AND SOFT SOLDER CENTER CONDUCTOR IN PLACE.
 3. CRIMP FERRULE. INSERT INSULATOR AND SCREW CAP.

THESE COMMODITIES, TECHNOLOGY OR SOFTWARE WERE EXPORTED FROM THE UNITED STATES IN ACCORDANCE WITH THE EXPORT ADMINISTRATION REGULATIONS, DIVERSION CONTRARY TO U.S. LAW PROHIBITED.



TITLE

UNLESS OTHERWISE SPECIFIED LEADING DIMENSIONS ARE INCHES		CABLE LENGTH (L) TOLERANCES:		THIRD-ANGLE PROJECTION	
DIMENSIONS IN [] ARE MILLIMETERS		CABLE LENGTH (L) TOLERANCES:		THE INFORMATION AND DESIGN IN THIS DOCUMENT IS THE PROPERTY OF FAIRVIEW MICROWAVE CORPORATION. ALL RIGHTS RESERVED.	
TOLERANCES:		CABLE LENGTH (L) TOLERANCES:		SHEET 1 OF 1	
X = ±.2	[.008]	FRACTIONS	L ≤ 12 [305] = +1 [25] / -0	SCALE	
XX = ±.02	[.51]	± 1/32	12 [305] < L ≤ 60 [1524] = +2 [51] / -0	N/A	
XXX = ±.005	[.13]	ANGLES ± 1°	60 [1524] < L ≤ 120 [3048] = +4 [102] / -0	REV A	
			120 [3048] < L ≤ 300 [7620] = +6 [152] / -0		
			300 [7620] < L = +5%L / -0		
SIZE	GAGE CODE	DRAWN BY	ITEM NO.	REV	
A	3FKRS	K.GLEBOVA	FMCN1822	A	
ALL DIMENSIONS SHOWN ARE FOR REFERENCE ONLY.					