

6 5 4 3 2 1

REVISION					
ZONE	REV	DESCRIPTION	DATE	CHANGED BY	APPROVED
	C	ECO-13942	12/19/2024	KDANG	SRAUTUS

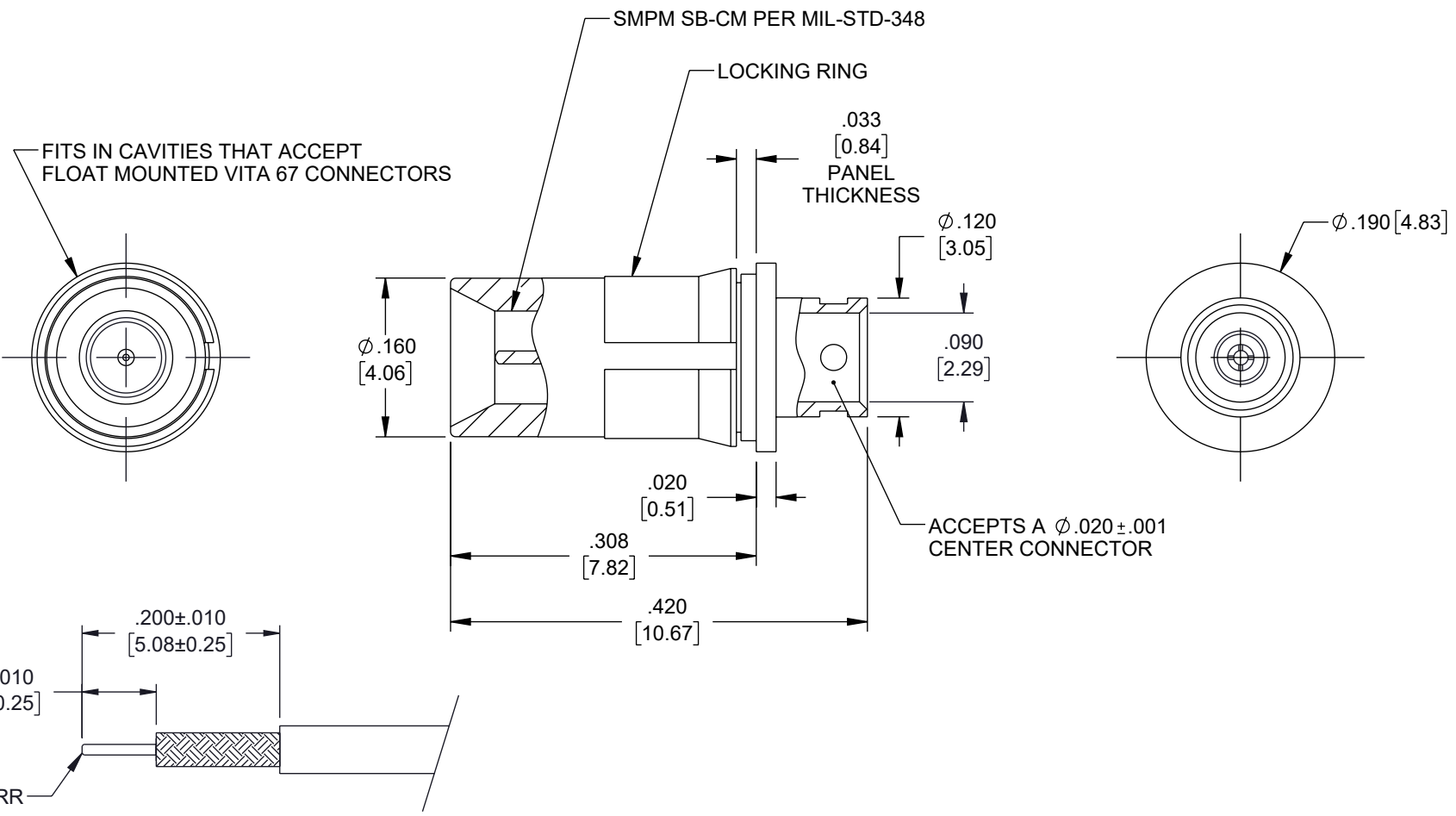

**ASSEMBLY PROCEDURES**

1. STRIP THE CABLE TO THE DIMENSIONS AS SHOWN, DO NOT NICK INNER CONDUCTOR.
2. INSERT THE CABLE FULLY SIT INTO THE BODY.
3. SOLDER OUTER CONDUCTOR WITH BODY. SOLDER COMPLETELY AROUND CABLE. NO VOIDS ALLOWED

THE INFORMATION CONTAINED IN THIS DRAWING IS THE SOLE PROPERTY OF INFINITE ELECTRONICS, INC. ANY REPRODUCTION IN PART OR WHOLE WITHOUT THE WRITTEN PERMISSION OF INFINITE ELECTRONICS, INC. IS PROHIBITED. THESE COMMODITIES, TECHNOLOGY OR SOFTWARE WERE EXPORTED FROM THE UNITED STATES IN ACCORDANCE WITH THE EXPORT ADMINISTRATION REGULATIONS. DIVERSION CONTRARY TO U.S. LAW PROHIBITED.

UNLESS OTHERWISE SPECIFIED LEADING DIMENSIONS ARE INCHES DIMENSIONS IN [ ] ARE MILLIMETERS

TOLERANCES:

X = ±.2 [5]	FRACTIONS ± 1/32
XX = ±.02 [0.5]	ANGLES ± 1°
.XXX = ±.005 [0.13]	

CABLE LENGTH TOLERANCES:

≤12 [305]	= +1 [25] / -0
>12 [305] ≤ 60 [1524]	= +2 [51] / -0
>60 [1524] ≤ 120 [3048]	= +4 [102] / -0
>120 [3048] ≤ 300 [7620]	= +6 [152] / -0
>300 [7620]	= +5% / -0

ALL DIMENSIONS ARE FOR REFERENCE ONLY AND SUBJECT TO CHANGE WITHOUT NOTICE UN-DIMENSIONED/NON-CRITICAL FEATURES MAY VARY IN SIZE AND LOCATION COLORS MAY VARY

**Fairview Microwave®**  
an INFINIT® brand

Website: [www.FairviewMicrowave.com](http://www.FairviewMicrowave.com)  
Phone: 1.800.715.4396 | 1.972.649.6678

INTERPRET ALL DIMENSIONS AND TOLERANCES PER ASME Y14.5

SCALE	SHEET
NONE	1 OF 1

DESCRIPTION

**MINI SMP MALE VITA 67 CONNECTOR SOLDER ATTACHMENT FOR FM-F086HF CABLE**

SIZE	CAGE CODE	DRAWN BY	ITEM NO.	REV
A	3FKR5	BPUCHASKI	FMCN1540	C

6 5 4 3 2 1