

**3.5mm MALE**

| STANDARD TOLERANCES |        |
|---------------------|--------|
| .X                  | ±0.2   |
| .XX                 | ±0.01  |
| .XXX                | ±0.005 |

\*STANDARD TOLERANCES APPLY ONLY TO DIMENSIONS IN INCHES

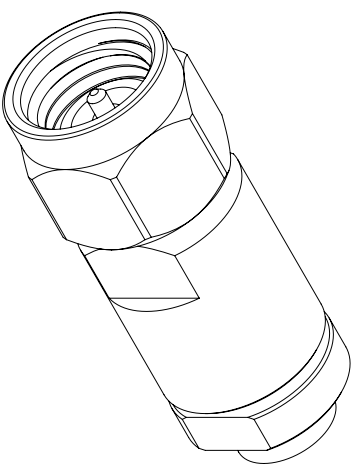

NOTES:  
 1. UNLESS OTHERWISE SPECIFIED ALL DIMENSIONS ARE NOMINAL.  
 2. ALL SPECIFICATIONS ARE SUBJECT TO CHANGE WITHOUT NOTICE AT ANY TIME.  
 3. DIMENSIONS ARE IN INCHES [mm].

|                    |  |          |        |           |      |
|--------------------|--|----------|--------|-----------|------|
| TITLE              |  | DWG NO   |        | CAGE CODE |      |
| Fairview Microwave |  | FMCN1424 |        | 3FKR5     |      |
| an INFINITT@ brand |  | CAD FILE | SHEET  | SCALE     | SIZE |
|                    |  | 05/13/19 | 1 OF 2 | N/A       | A    |
|                    |  |          |        |           | 7361 |