

ASSEMBLY PROCEDURES

1. STRIP CABLE AS SHOWN, CHAMFER CENTER CONDUCTOR & DEBURR CABLE.
2. INSERT INSULATOR CLIP, INSERT CENTER CONTACT AND SOLDER. WRAP THE CABLE BY SOLDER WIRE (Dia 1.2mm).
3. PUSH THE CONNECTOR BODY INTO THE CABLE, UNTIL IT STOPS. SOLDER THE CONNECTOR BODY WITH CABLE.

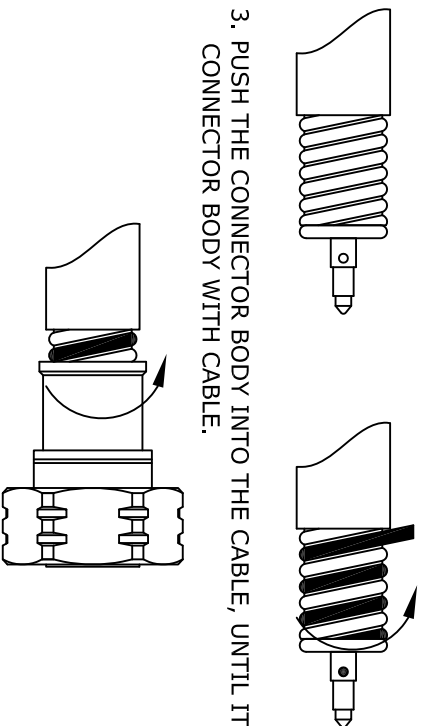

STANDARD TOLERANCES	
.X	±0.2
.XX	±0.1
.XXX	±0.05

*STANDARD TOLERANCES APPLY ONLY TO DIMENSIONS IN INCHES

FAIRVIEW MICROWAVE INC.
ALLEN, TX 75013 WWW.FAIRVIEWMICROWAVE.COM

NOTES:
1. UNLESS OTHERWISE SPECIFIED ALL DIMENSIONS ARE NOMINAL.
2. ALL SPECIFICATIONS ARE SUBJECT TO CHANGE WITHOUT NOTICE AT ANY TIME.
3. DIMENSIONS ARE IN INCHES [mm].

TITLE		DWG NO		CAGE CODE	
		FMCN1169		3FKR5	
CAD FILE	012017	SHEET		SCALE	N/A
				SIZE	A
					2233