

6

5

4

3

2

1

REVISION

ZONE	REV	DESCRIPTION	DATE	CHANGED BY	APPROVED
	B	ECO-13202	04/16/2024	KGLEBOVA	KHIETPAS

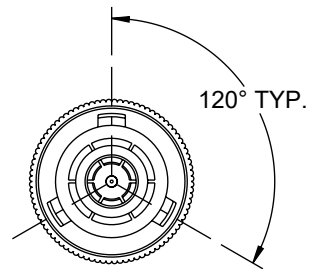
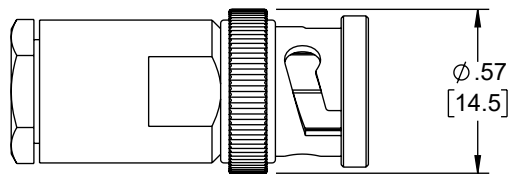
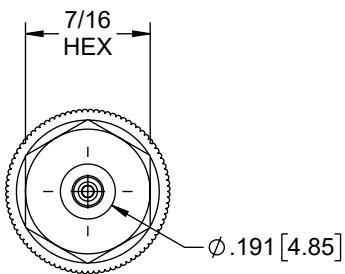
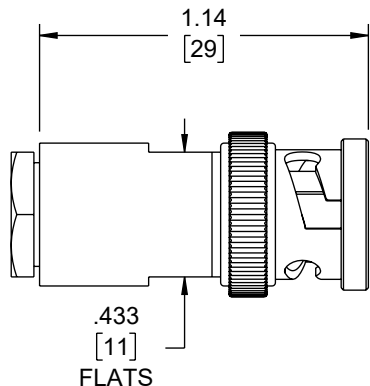

UNLESS OTHERWISE SPECIFIED
LEADING DIMENSIONS ARE INCHES
DIMENSIONS IN [] ARE MILLIMETERS

TOLERANCES:
X = ±.2 [5] FRACTIONS ± 1/32
.XX = ±.02 [0.5] ANGLES ± 1°
.XXX = ±.005 [0.13]

CABLE LENGTH TOLERANCES:
≤12 [305] = +1 [25] / -0
>12 [305] ≤ 60 [1524] = +2 [51] / -0
>60 [1524] ≤ 120 [3048] = +4 [102] / -0
>120 [3048] ≤ 300 [7620] = +6 [152] / -0
>300 [7620] = +5% / -0

ALL DIMENSIONS ARE FOR REFERENCE ONLY
AND SUBJECT TO CHANGE WITHOUT NOTICE
UN-DIMENSIONED/NON-CRITICAL FEATURES
MAY VARY IN SIZE AND LOCATION
COLORS MAY VARY



Website: www.FairviewMicrowave.com
Phone: 1.800.715.4396 | 1.972.649.6678

INTERPRET ALL DIMENSIONS AND TOLERANCES PER ASME Y14.5

SCALE	SHEET
NONE	1 OF 2

DESCRIPTION
50 OHM TRB 3-SLOT PLUG 1553 CONNECTOR CLAMP/SOLDER ATTACHMENT FOR TRC-50-1

THE INFORMATION CONTAINED IN THIS DRAWING IS THE SOLE PROPERTY OF INFINITE ELECTRONICS, INC. ANY REPRODUCTION IN PART OR WHOLE WITHOUT THE WRITTEN PERMISSION OF INFINITE ELECTRONICS, INC. IS PROHIBITED. THESE COMMODITIES, TECHNOLOGY OR SOFTWARE WERE EXPORTED FROM THE UNITED STATES IN ACCORDANCE WITH THE EXPORT ADMINISTRATION REGULATIONS. DIVERSION CONTRARY TO U.S. LAW PROHIBITED.

SIZE	CAGE CODE	DRAWN BY	ITEM NO.	REV
A	3FKR5	SREITER	FMCN10-06030-370	B

6

5

4

3

2

1

6

5

4

3

2

1

ASSEMBLY INSTRUCTIONS

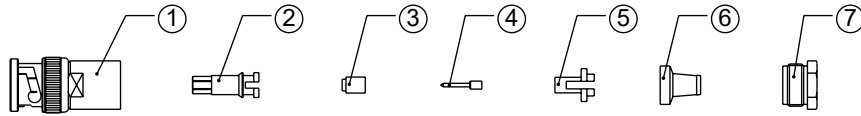

- ① BODY ASSEMBLY
- ② INNER SHIELD
- ③ DIELECTRIC
- ④ CONTACT

- ⑤ CONE INSERT
- ⑥ CONE
- ⑦ CLAMP NUT

STEP 1

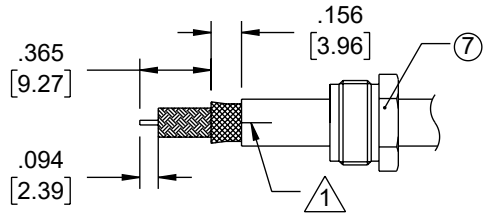

1. PLACE ⑦ ONTO CABLE.
2. STRIP CABLE AS SHOWN AND FLARE BRAID TO ALLOW FREE ENTER OF ⑥. (△1 LATERAL SLITS 180° APART MAY BE REQUIRED FOR VERY INFLEXIBLE JACKET MATERIALS).
3. LIGHTLY TIN CENTER CONDUCTOR.

STEP 3

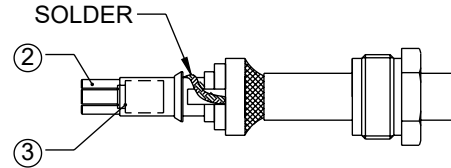

1. PLACE ③ OVER ④ UNTIL BOTTOMED.
2. INSTALL ② OVER ③ & ⑤ WITH PIGTAIL THROUGH NOTCHES.
3. WRAP PIGTAIL BETWEEN ② RIDGES AND SOLDER (DO NOT ALLOW PIGTAIL AND SOLDER TO EXTEND ABOVE ② RIDGES).

STEP 2

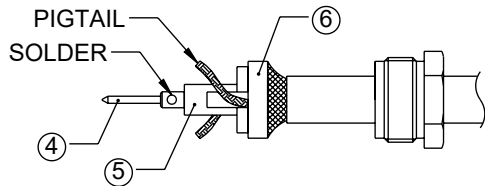

1. PUSH ⑥ UNDER OUTER BRAID UNTIL BRAID IS FLUSH WITH EDGE OF ⑥. TRIM ANY ERRANT STRANDS.
2. SEPARATE INNER BRAID AND PIGTAIL BOTH SIDES.
3. INSTALL ⑤ INTO ⑥ WITH PIGTAIL THROUGH SIDES.
4. POSITION ④ AND SOLDER IN PLACE.

STEP 4

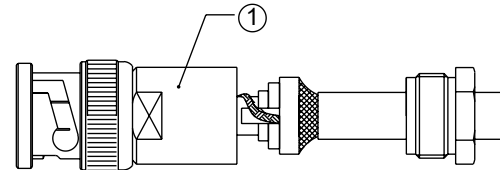

1. BRING ⑦ UP ONTO TAPERED PORTION OF ⑥.
2. ASSEMBLE ① OVER ENTIRE ASSY AND ENGAGE WITH ⑦.
3. WRENCH TIGHTEN TO 25-35 IN LBS TORQUE.



Website: www.FairviewMicrowave.com
 Phone: 1.800.715.4396 | 1.972.649.6678

INTERPRET ALL DIMENSIONS AND TOLERANCES PER ASME Y14.5
 SCALE NONE SHEET 2 OF 2

DESCRIPTION
 50 OHM TRB 3-SLOT PLUG 1553 CONNECTOR CLAMP/SOLDER ATTACHMENT FOR TRC-50-1

SIZE A	CAGE CODE 3FKR5	DRAWN BY SREITER	ITEM NO. FMCN10-06030-370	REV B
-----------	--------------------	---------------------	------------------------------	----------

THE INFORMATION CONTAINED IN THIS DRAWING IS THE SOLE PROPERTY OF INFINITE ELECTRONICS, INC. ANY REPRODUCTION IN PART OR WHOLE WITHOUT THE WRITTEN PERMISSION OF INFINITE ELECTRONICS, INC. IS PROHIBITED. THESE COMMODITIES, TECHNOLOGY OR SOFTWARE WERE EXPORTED FROM THE UNITED STATES IN ACCORDANCE WITH THE EXPORT ADMINISTRATION REGULATIONS. DIVERSION CONTRARY TO U.S. LAW PROHIBITED.

ALL DIMENSIONS ARE FOR REFERENCE ONLY AND SUBJECT TO CHANGE WITHOUT NOTICE UN-DIMENSIONED/NON-CRITICAL FEATURES MAY VARY IN SIZE AND LOCATION COLORS MAY VARY