

6

5

4

3

2

1

REVISION					
ZONE	REV	DESCRIPTION	DATE	CHANGED BY	APPROVED
	A	INITIAL RELEASE	06/26/2023	KGLEBOVA	AGANWANI

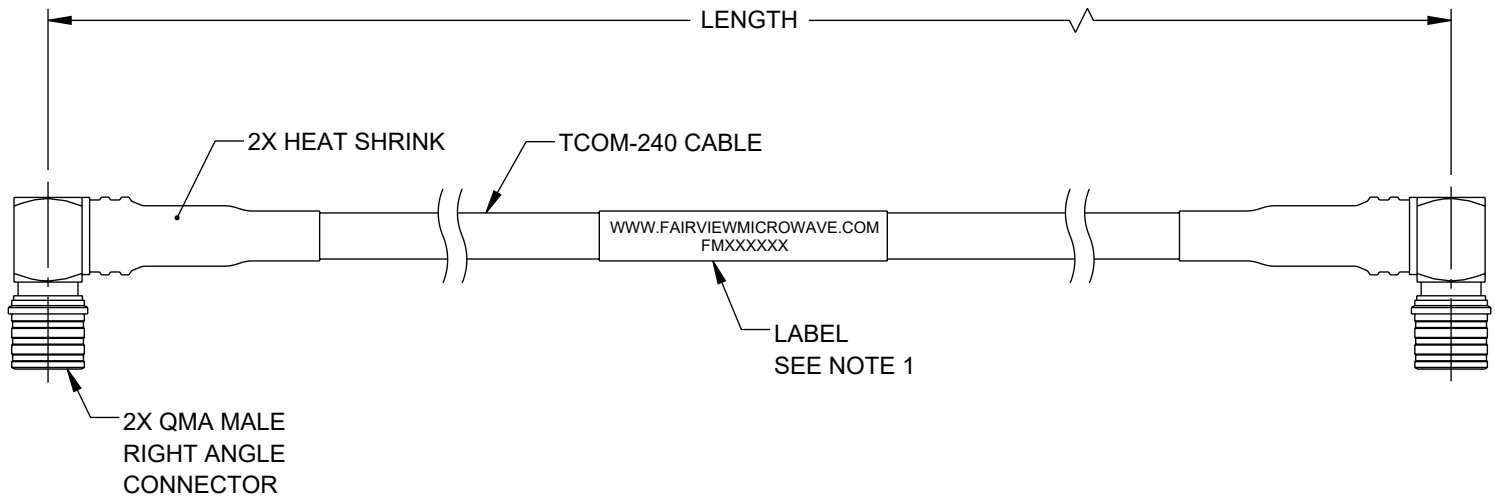

NOTES:

- CABLE ASSEMBLY LENGTH LABEL PLACEMENT:
36 INCHES OR LESS, ONE LABEL APPROXIMATELY CENTERED.
LONGER THAN 36 INCHES, TWO LABELS APPROXIMATELY 6 INCHES FROM EACH CONNECTOR.
- CABLES ASSEMBLIES SHALL BE TESTED FOR CONTINUITY.

UNLESS OTHERWISE SPECIFIED LEADING DIMENSIONS ARE INCHES DIMENSIONS IN [] ARE MILLIMETERS

TOLERANCES:

.X = ±.2 [5]	FRACTIONS ± 1/32
.XX = ±.02 [0.5]	ANGLES ± 1°
.XXX = ±.005 [0.13]	

CABLE LENGTH TOLERANCES:

≤12 [305]	≤60 [1524]	≤120 [3048]	≤300 [7620]	>300 [7620]
= +1 [25] / -0	= +2 [51] / -0	= +4 [102] / -0	= +6 [152] / -0	= +5% / -0

ALL DIMENSIONS ARE FOR REFERENCE ONLY AND SUBJECT TO CHANGE WITHOUT NOTICE. UN-DIMENSIONED/NON-CRITICAL FEATURES MAY VARY IN SIZE AND LOCATION. COLORS MAY VARY.

Fairview Microwave®
an INFINIT® brand

Website: www.FairviewMicrowave.com
Phone: 1.800.715.4396 | 1.972.649.6678

<p>INTERPRET ALL DIMENSIONS AND TOLERANCES PER ASME Y14.5</p>	
SCALE	SHEET
NONE	1 OF 1

DESCRIPTION
LOW LOSS QMA MALE RIGHT ANGLE TO QMA MALE RIGHT ANGLE CABLE USING TCOM-240 COAX WITH TIMES MICROWAVE COMPONENTS

THE INFORMATION CONTAINED IN THIS DRAWING IS THE SOLE PROPERTY OF INFINITE ELECTRONICS, INC. ANY REPRODUCTION IN PART OR WHOLE WITHOUT THE WRITTEN PERMISSION OF INFINITE ELECTRONICS, INC. IS PROHIBITED. THESE COMMODITIES, TECHNOLOGY OR SOFTWARE WERE EXPORTED FROM THE UNITED STATES IN ACCORDANCE WITH THE EXPORT ADMINISTRATION REGULATIONS. DIVERSION CONTRARY TO U.S. LAW PROHIBITED.

SIZE	CAGE CODE	DRAWN BY	ITEM NO.	REV
A	3FKR5	KGLEBOVA	FMCA3295	A

6

5

4

3

2

1