

6

5

4

3

2

1

REVISION					
ZONE	REV	DESCRIPTION	DATE	CHANGED BY	APPROVED
	B	ECO-13621	6/11/2024	KDANG	AGANWANI

F

F

E

E

D

D

C

C

B

B

A

A

LENGTH
SEE NOTE 2

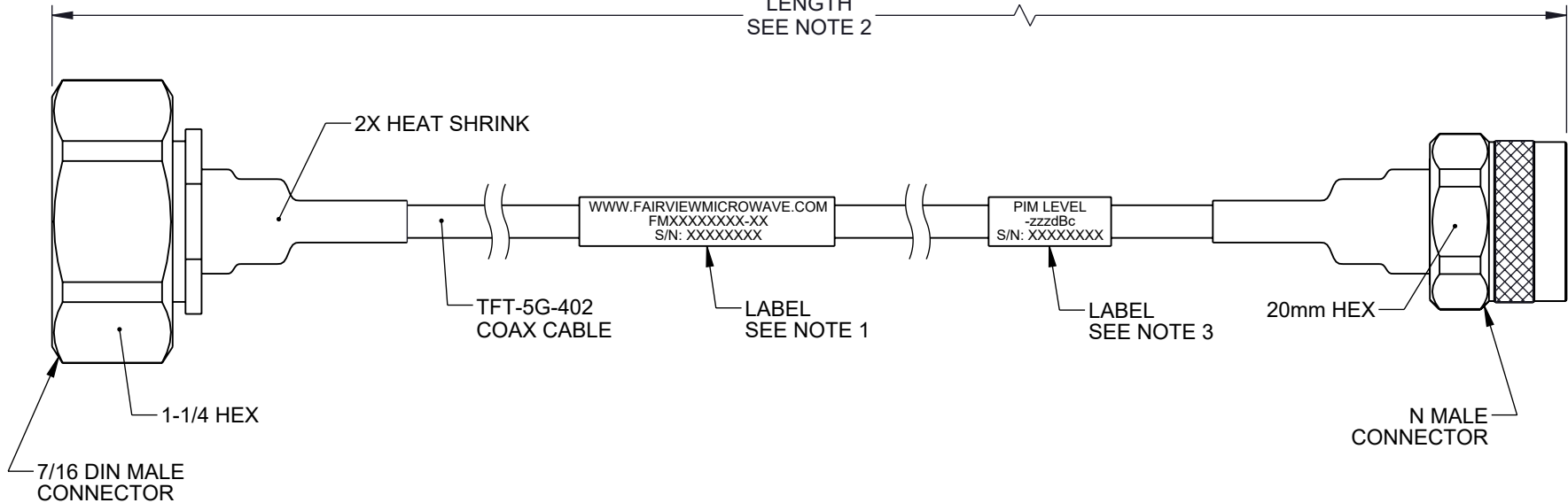

NOTES:

1. CABLE ASSY LENGTH LABEL PLACEMENT: CABLES 84" OR LESS, ONE LABEL APPROX CENTERED. LONGER THAN 84 INCHES, TWO LABELS APPROX 12 INCHES FROM EACH CONNECTOR.
2. CABLE ASSEMBLY LENGTH DETERMINED BY ITEM PN AND DESCRIPTION.
3. PIM LEVEL LABEL PLACEMENT: APPROX 6 INCHES FROM CABLE END, 1 PLACE, FOR ALL LENGTHS OF CABLE.
4. CABLES ASSEMBLIES SHALL BE TESTED FOR CONTINUITY.

THE INFORMATION CONTAINED IN THIS DRAWING IS THE SOLE PROPERTY OF INFINITE ELECTRONICS, INC. ANY REPRODUCTION IN PART OR WHOLE WITHOUT THE WRITTEN PERMISSION OF INFINITE ELECTRONICS, INC. IS PROHIBITED. THESE COMMODITIES, TECHNOLOGY OR SOFTWARE WERE EXPORTED FROM THE UNITED STATES IN ACCORDANCE WITH THE EXPORT ADMINISTRATION REGULATIONS. DIVERSION CONTRARY TO U.S. LAW PROHIBITED.

UNLESS OTHERWISE SPECIFIED LEADING DIMENSIONS ARE INCHES DIMENSIONS IN [] ARE MILLIMETERS	
TOLERANCES:	
X = ±.2 [5]	FRACTIONS ± 1/32
.XX = ±.02 [0.5]	ANGLES ± 1°
CABLE LENGTH TOLERANCES:	
≤12 [305]	= +1 [25] / -0
>12 [305] ≤ 60 [1524]	= +2 [51] / -0
>60 [1524] ≤ 120 [3048]	= +4 [102] / -0
>120 [3048] ≤ 300 [7620]	= +6 [152] / -0
>300 [7620]	= +5% / -0
ALL DIMENSIONS ARE FOR REFERENCE ONLY AND SUBJECT TO CHANGE WITHOUT NOTICE UN-DIMENSIONED/NON-CRITICAL FEATURES MAY VARY IN SIZE AND LOCATION COLORS MAY VARY	

<p>Fairview Microwave® an INFINIT® brand</p>		<p>INTERPRET ALL DIMENSIONS AND TOLERANCES PER ASME Y14.5</p>	
<p>Website: www.FairviewMicrowave.com Phone: 1.800.715.4396 1.972.649.6678</p>		SCALE NONE	SHEET 1 OF 1
<p>DESCRIPTION LOW PIM 7/16 DIN MALE TO N MALE CABLE TFT-5G-402 COAX USING TIMES MICROWAVE COMPONENTS</p>			
SIZE A	CAGE CODE 3FKR5	DRAWN BY KDANG	ITEM NO. FMCA2508
			REV B

6

5

4

3

2

1