

6 5 4 3 2 1

REVISION					
ZONE	REV	DESCRIPTION	DATE	CHANGED BY	APPROVED
	B	UPDATED PER ECO-13622	06/10/2024	HBAKKE	SRAUTUS

F F

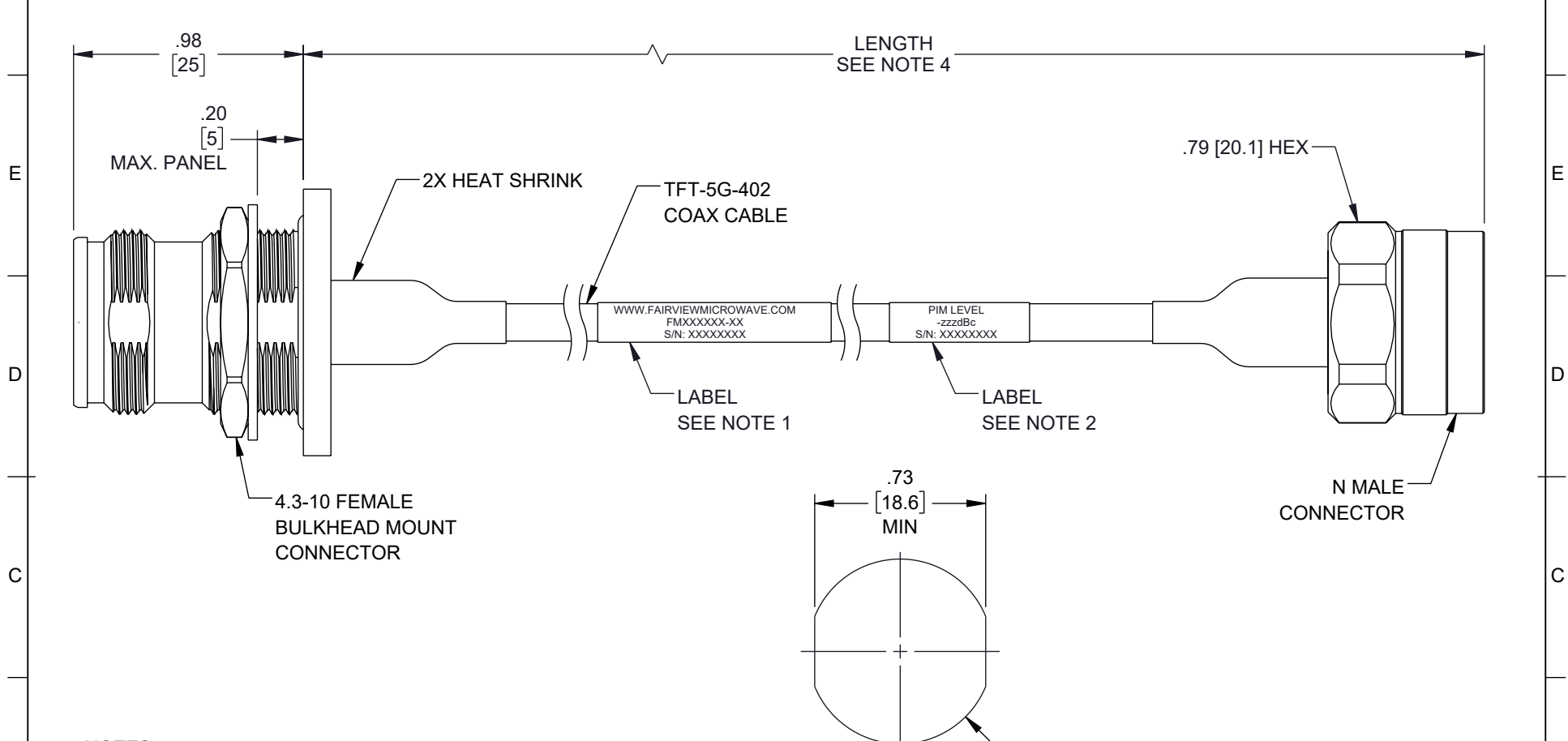

C C

NOTES:

1. CABLE ASSEMBLY LENGTH LABEL PLACEMENT: CABLES 84 INCHES OR LESS, ONE LABEL APPROXIMATELY CENTERED. LONGER THAN 84 INCHES, TWO LABELS APPROXIMATELY 12 INCHES FROM EACH CONNECTOR.
2. PIM LEVEL LABEL PLACEMENT: APPROXIMATELY 6 INCHES FROM CABLE END, 1 PLACE, FOR ALL LENGTHS OF CABLE.
3. CABLE ASSEMBLIES SHALL BE TESTED FOR CONTINUITY.
4. CABLE ASSEMBLY LENGTH DETERMINED BY ITEM PN AND DESCRIPTION.

RECOMMENDED MOUNTING HOLE

A

THE INFORMATION CONTAINED IN THIS DRAWING IS THE SOLE PROPERTY OF INFINITE ELECTRONICS, INC. ANY REPRODUCTION IN PART OR WHOLE WITHOUT THE WRITTEN PERMISSION OF INFINITE ELECTRONICS, INC. IS PROHIBITED. THESE COMMODITIES, TECHNOLOGY OR SOFTWARE WERE EXPORTED FROM THE UNITED STATES IN ACCORDANCE WITH THE EXPORT ADMINISTRATION REGULATIONS. DIVERSION CONTRARY TO U.S. LAW PROHIBITED.

UNLESS OTHERWISE SPECIFIED LEADING DIMENSIONS ARE INCHES DIMENSIONS IN [] ARE MILLIMETERS	
TOLERANCES:	
X = ±.2 [5]	FRACTIONS ± 1/32
XX = ±.02 [0.5]	ANGLES ± 1°
.XXX = ±.005 [0.13]	
CABLE LENGTH TOLERANCES:	
≤12 [305] = +1 [25] / -0	
>12 [305] ≤ 60 [1524] = +2 [51] / -0	
>60 [1524] ≤ 120 [3048] = +4 [102] / -0	
>120 [3048] ≤ 300 [7620] = +6 [152] / -0	
>300 [7620] = +5% / -0	
ALL DIMENSIONS ARE FOR REFERENCE ONLY AND SUBJECT TO CHANGE WITHOUT NOTICE UN-DIMENSIONED/NON-CRITICAL FEATURES MAY VARY IN SIZE AND LOCATION COLORS MAY VARY	

Fairview Microwave®
an INFINIT® brand

Website: www.FairviewMicrowave.com
Phone: 1.800.715.4396 | 1.972.649.6678

DESCRIPTION
LOW PIM 4.3-10 FEMALE BULKHEAD TO N MALE CABLE TFT-5G-402 COAX USING TIMES MICROWAVE COMPONENTS

SIZE A	CAGE CODE 3FKR5	DRAWN BY MVEERAPPAN	ITEM NO. FMCA2494	REV B
-----------	--------------------	------------------------	----------------------	----------

INTERPRET ALL DIMENSIONS AND TOLERANCES PER ASME Y14.5	
SCALE NONE	SHEET 1 OF 1

6 5 4 3 2 1